



MAXIMUM PROTECTION FOR OPERATORS AND ENVIRONMENTS

Bioreset Max is the new vapor-phase hydrogen peroxide (VHP) generator offering the maximum **protection for operators and environments from viruses and microorganisms**. It is easy to use and extremely effective thanks to an advanced technology applied for years in controlled contamination environments.



LIGHT, HANDY, FOOLPROOF

Made entirely of stainless steel and ABS, it is lightweight and easily transportable. Its small size makes it a winning ally for all applications where a compact and handy equipment is required to help the operator moving even in small spaces.

Thanks to the automatic cycle, the tool is extremely user-friendly and allows to reach optimal levels of efficacy with each use.

APPLICATIONS

- Biosafety cabinet
- Hospitals and healthcare facilities
- Dental and medical clinics
- Microbiological laboratories
- Biosafety laboratories
- Biomedical research facilities

Bioreset[®]Max



HOW IT WORKS

Surfaces and environments

Inserted in the area to be decontaminated, Bioreset Max generates the sterilizing agent in vapor phase. The gas spreads in perfectly uniform way, reaching even the most difficult points and ensuring a very high level of reduction of the microbial load (up to 6 Log) on all exposed surfaces.

No further pre- or post-cycle activity is required. By pressing a button, it is possible to launch in fully automatic mode the cycle for the biodecontamination of areas up to 350 m³ with a process managed by a probe and remotely controlled by personal computer, tablet and smartphone.

At the end of the cycle, the catalyst allows the aeration of the environment without the need for forced ventilation and transforms the decontamination agent into water and oxygen.



Biosafety cabinet

The primary purpose of a biosafety cabinet (BSC) is to serve as a means to protect the operator and the surrounding environment from pathogens and to ensure absolute sterility conditions.

When maintenance is carried out, for example to replace HEPA filter, it is essential to decontaminate the BSC before proceeding with any activity. Particular attention should be paid to the decontamination of filters as they are a possible point of presence of pathogens.

Bioresat Max, using hydrogen peroxide in vapor phase, can sterilize all exposed surfaces up to 6 Log, including HEPA filters.

FEATURES

- Made of stainless steel and ABS
- Integrated 7" colour touch panel, simple and intuitive
- Communication via Ethernet connection for remote control
- Vaporizer capacity from 5 to 10 gr/min
- Reports exported via USB port
- Automatic cycle adjusted according to H₂O₂ ppm level
- Catalyst with integrated blower with nominal airflow up to 650 m³/h

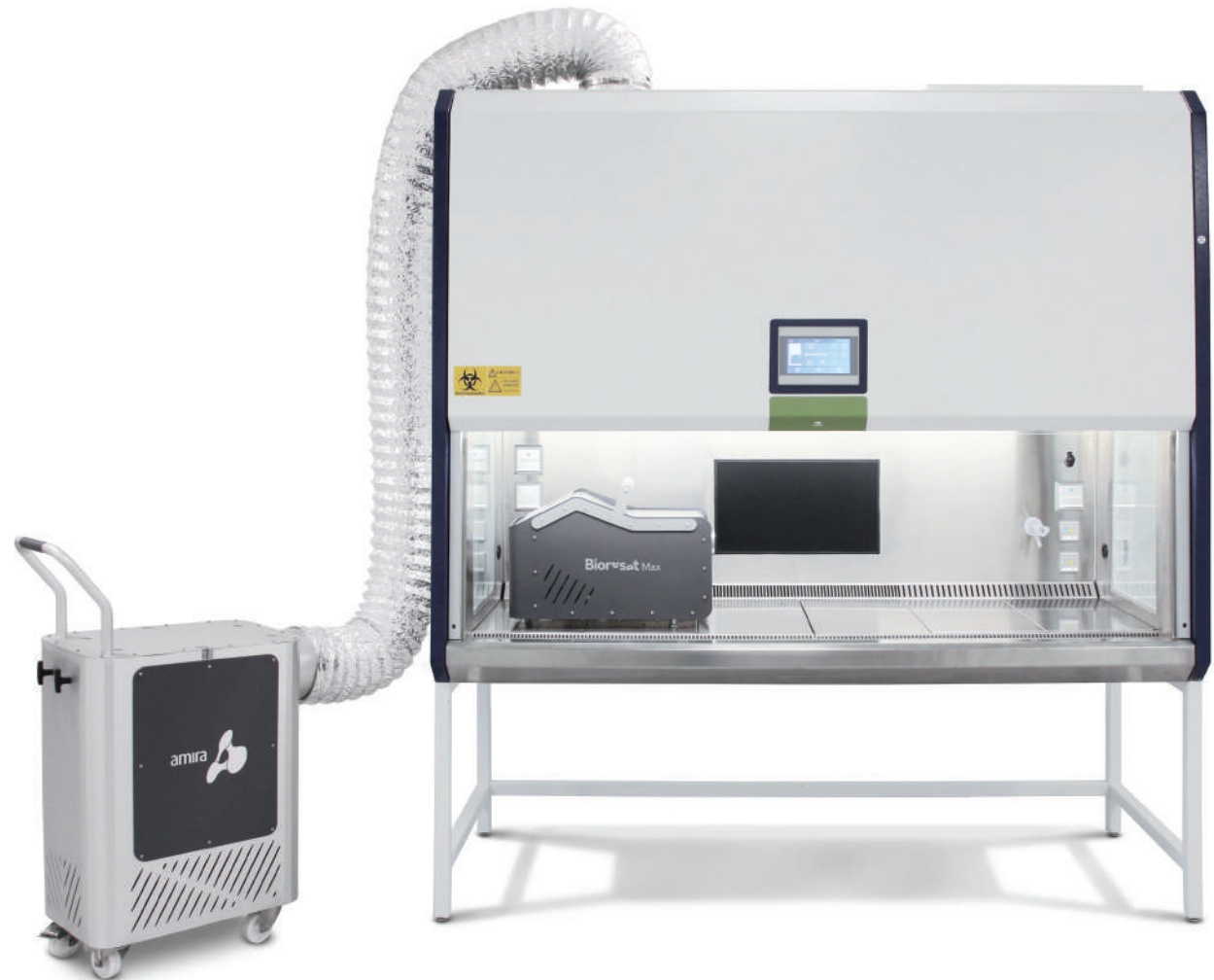

Technical data - Bioreset Max

Max treatable volume*	Up to 350 m ³
T/RS%-PPM probe	+5°C ... +50°C - step 0,1°C 0% ... 100% RS - step 0,1% 0 ... 2000 ppm - step 1 ppm
Peristaltic pump	Integrated 5 ... 10 g/min
Remote control	PC
Materials	Stainless steel AISI 316 and ABS
Power supply	230V / 50Hz o 110V / 60Hz
Max consumption	1 kW
Dimensions (W x D x H)	565 x 265 x 375 mm
Weight	15,5 kg

Technical data - Catalyst

Ø inlet connection	200 mm
Max nominal airflow	Up to 650 m ³ /h
Dimensions (W x D x H)	710 x 354 x 1.030 mm
Weight	33 kg

* clean, dry, sealed enclosures

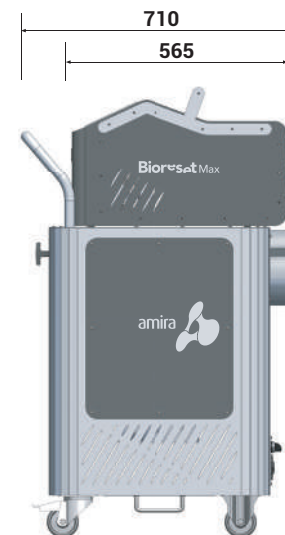
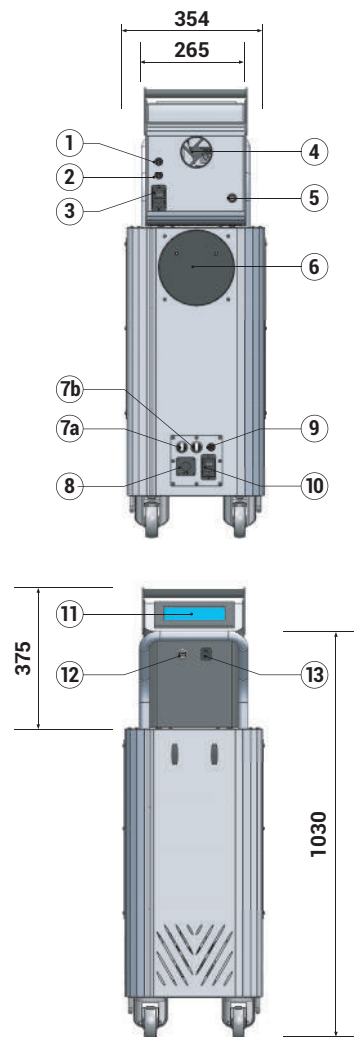

Legenda

- 1 PPM T/RS% probe
- 2 Connection with catalyst (9)
- 3/10 Power supply
- 4 VHP output
- 5 H₂O₂ inlet
- 6 Catalyst air inlet
- 7a Automatic / manual mode
- 7b BSC / room mode
- 8 Additional power supply
- 9 Connection with Bioreset Max (2)
- 11 Touch screen
- 12 USB interface
- 13 Ethernet interface